

Maths in the workplace

Richard Browne and Chris Robbins – MEI
Amy Adam - Thales



Overview

- Background
 - MEI Industry programme
 - FMSP Maths at Work events
 - Exemplars
- 3-D Coordinate systems
 - Presentation by Amy Adam, Thales
 - Discussion
- Graph Theory
 - Presentation by Amy Adam, Thales
 - Discussion



MEI Industry programme

- The programme is aiming to get industry to take advantage of MEI's educational expertise in the workplace
- It is also involved in several initiatives intended to enrich mathematics learning by providing information about ways mathematics is used in the workplace



FMSP Maths at Work events

- MEI manages the Further Mathematics Support Programme (FMSP) for the DfE
- FMSP Area Coordinators have provided a number of enrichment events for students in Y10 and Y12 that give them insight into mathematics in the workplace



Exemplars

- The FMSP supports level 3 mathematics learning in the diplomas, particularly the Engineering Diploma
- The Royal Academy of Engineering has provided MEI with funding to develop support material for the Engineering Diploma
- The majority of this effort will be on producing exemplars



Maths at Work Conference



■ Typical Programme

9.00-9.30	Registration/Welcome/Introduction
9.30	Session 1
10.30	Break (drinks provided)
10.45	Session 2
11.45	Lunch (visitors to bring a packed lunch)
12.15	Tour of campus – group sizes 10/12
13.15	Session 3
14.15	Break (drinks provided)
14.30	Session 4
15.30–15.45	Plenary session and concluding remarks

I am an Engineer – this is what I do Conferences



Speakers

Brian Newsome & Lynda Alwood	Former Research Officer) Former Research Officer) Powergen/CEGB
Chris Robbins & Claire Sedgewick	Consultant Engineer, Grallator Student Ambassador, The Dept of Civil Engineering, The University of Sheffield
Nigel Stephenson & Emma Watson	Technical Manager) Stress Engineer) Rolls Royce, Derby
Rik Stewart & Jolene Costello	Senior Design Engineer) Jacobs, Senior Engineer, Transport and Development) Nottm.

Maths at Work Conference



Speakers – key issues

- What they intend to do
- How they will do it:
 - Well structured presentation important
 - An interactive approach is essential
- Pitching the presentation at the correct level:
 - Presenters need to be made aware of the participating students' current mathematical abilities

Exemplars

- MEI's work on exemplars will be carried out by Chris Robbins
- Chris has been a longstanding contributor to the Maths at Work initiative
- He also contributed to a conference MEI held with the Institution of Engineering and Technology last year

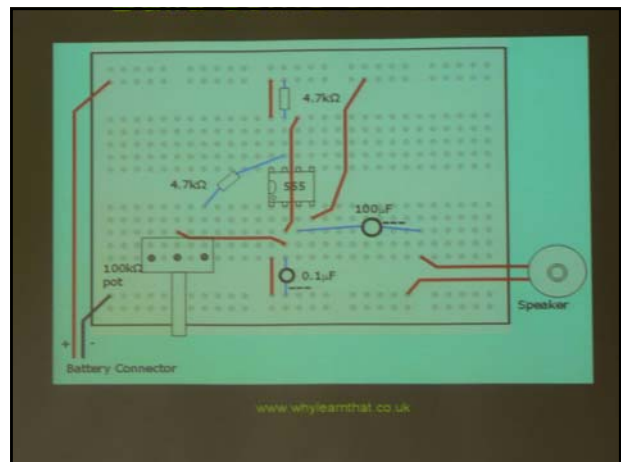

I am now delighted to introduce

Amy Adam

MEI **THALES**





MEI Conference July 2nd 2010
 Mathematics in the Defence Industry – 3D Coordinate Systems and Graph Theory

Land Defence

Background

Amy Adam

- Education –
 - Mathematics and Statistics BSc 
 - Ongoing part-time MSc in Digital Signal Processing 
- Industry –
 - Modelling and Algorithms Engineer with **Thales Missile Electronics** (2008 –Present).
 - Primarily defence research and de-risking activities.

2 Land Defence **THALES**

Application of Topics in the Defence Industry

- 3D Coordinate Systems
 - Practical Use
 - Terminology
 - Software Generated Simulation
- Graph Theory
 - Programme Management
 - Task Breakdown
 - Resource Allocation
 - Budgeting
 - Risk Analysis

3 Land Defence **THALES**

3D Coordinate Systems

4 Land Defence **THALES**

Practical Use

- Aviation Metrics
- Weapon Guidance Systems
- Navigation
 - Naval
 - Aerospace



These technologies all rely on a standardisation of axes systems
 >Unfortunately the academic and the engineering definitions don't always match!

5 Land Defence **THALES**

3D Coordinate Systems - Terminology

In the classroom

Visualisation can be tricky when linking from 2D to 3D

$[\sigma, \theta, \psi]$ abstract context

What direction are we rotating in?

Is it a left-handed system or a right-handed system?

In industry

3D visualisation tools

Descriptive angle and axes definitions

yaw

elevation

pitch

radians

heading

bank

roll

degrees

N
 W E
 S

6 Land Defence **THALES**

Rotation Simulation

Plane before rotation

z/Altitude
y/East x/North

THALES

Rotation Simulation

There will be a few slides showing the plane rotating.
I haven't managed to get the video files in a compatible format yet but it won't be a problem

THALES

3D Infrared Imaging

Double Click to play!

Software code triggers the mechanics of the gimbals.

THALES

The issue can get complicated very quickly!

Start with a global frame of reference. Where the origin is a convenient latitude, longitude

We have seen the plane rotating on this axis

We may have a sensor rotating in on the plane's axis

[latitude, longitude]

What is the 'plane's axis'?

Links nicely to cross products, basis and orthogonality.

THALES

The Programme Management Plan

balances –

- Task Breakdown
- Resource Allocation
- Budgeting
- Risk Analysis

THALES

Graph Theory

■ Abstract Context

Task A depends on completion of tasks B and D

Task B depends on completion of tasks C and D

■ Programme Management

Vast network of task completion dependencies

Tasks are also constrained by –

- Start and finish times
- Duration
- Availability of resources

Applying software like Microsoft Project Planner provides a top level view of the project

THALES

Graph Theory in Action

- Sound project management greatly increases efficiency and can save the project budget millions on large scale projects.
- The critical path is the driving force of a project. Once we have a task dependency breakdown we identify this path.

13 Land Defence

THALES

Task breakdown Example

Task Breakdown	T0	T0+1	T0+2	T0+3	T0+4	T0+5	T0+6	T0+7	T0+8
1. Preliminary Tasks									
1.1 Create PSM									
1.2 Define CADs									
2. System Development									
2.1 Coding									
2.1.1 Complete Tutorial program on MP/Lab									
2.1.2 Understand Centre program on MP/Lab									
2.2 Shoring									
2.2.1 Complete Tutorial									
2.2.2 Understand Shoring program on MP/Lab									
2.2.3 Create straight line code									
2.2.4 Develop test method for code and use it to test									
2.2.5 Expand code to use all sensors and follow curved									
2.2.6 Test and iterate code									
2.3 Motor									
2.3.1 Complete Tutorial									
2.3.2 Understand Motor program on MP/Lab									
3. Hardware Assembly									
3.1 Assemble sensors									
3.2 Assemble chassis/motor									
3.4 Assemble circuit boards									
3.5 Run test checks for structural/electrical									
4. Review/Validation									
4.1 PSM									
4.2 CADs									
4.3 PSM									
4.4 CAE									

14 Land Defence

THALES

Critical Path – The Maths

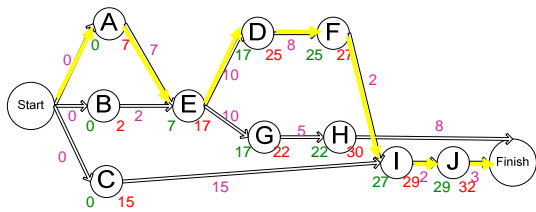

15 Land Defence

THALES

How can we introduce this into the classroom

- Pupils need to be aware of the advantage maths gives them in industry –
 - Engineers employed by Thales are sourced from a wide range of disciplines.
- Software tools
- Interaction between departments such as physics, chemistry and design.

16 Land Defence

THALES